

Interlink Electronics FSR[®] Force Sensing Resistors[®]

Force Sensing Linear Potentiometer (FSLP) Integration Guide

Table of Contents

1.0	Introduction.....	1
2.0	Scope.....	1
3.0	Theory of Operation	2
4.0	Mounting and Connection	5
4.1	Mounting.....	5
4.2	FSLP Types.....	5
4.3	Crimp Terminal Connections (10cm and derivatives only)	7
4.4	FFC Connection Method	8
5.0	Measurement Techniques and Algorithms.....	9
5.1	Measuring Position.....	10
5.2	Measuring Pressure	10
6.0	Actuator.....	12
7.0	Orderable Part Numbers	12
8.0	Intellectual Property & Other Legal Matters.....	12
9.0	Contact Interlink Electronics	13

1.0 Introduction

The Interlink Electronics Standard Force Sensing Linear Potentiometer (FSLP) is a linear position sensor for menu navigation and control. It functions as a linear potentiometer with the ability to detect a user's force for variable rate scrolling and a more intuitive user experience. The FSLP is an easy to integrate, high resolution, ultra low-power package ideal for media players, mobile phones, control panels, medical instruments and home entertainment devices. Measurement is simple enough that it can be accomplished directly with the device's host processor without the need for a dedicated microprocessor.

The purpose of this document is to guide users through the successful integration of the Interlink Electronics FSLP.

2.0 Scope

This Integration Guide provides the OEM integrator with all of the necessary technical information to successfully integrate the FSLP into products such as:

- Personal media players
- Mobile phones
- Control panels
- Medical instruments
- Home entertainment devices

Sensor part number is detailed in section 7.

3.0 Theory of Operation

The most basic Force Sensing Resistor (FSR) consists of two membranes separated by a thin air gap. The air gap is maintained by a spacer around the edges and by the rigidity of the two membranes. One of the membranes has two sets of fingers which are interdigitated and electrically distinct; each set connects to one trace on the tail. The other membrane is coated with FSR ink. When the two layers are pressed together, the FSR ink shorts the two traces together with a resistance that depends on applied force.

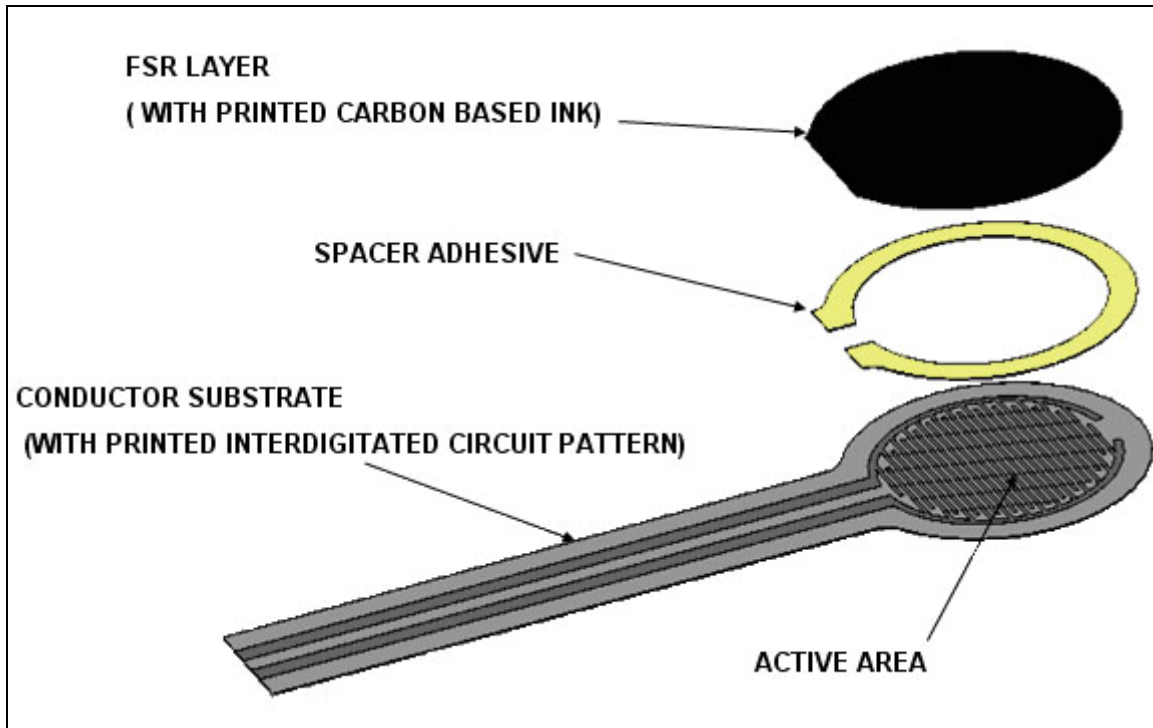

Figure 1: Exploded view of a standard single-zone FSR

Like the basic single-zone FSR, the Interlink Electronics FSLP has an FSR ink layer and a conductor substrate layer separated by an adhesive spacer. The FSLP's conductor layer however, is not simply a set of interdigitated silver fingers; it consists of two drive lines connected to either end of a printed fixed resistor and a sense line. Silver fingers orthogonally protrude along the entire length of the fixed resistor. These silver fingers are interdigitated with the sense line. When the FSR ink and conductor membranes are pressed together, the sense line is shorted to a point along the fixed resistor through the orthogonally protruding fingers. The resistance from either drive line to the touch point is proportional to the location of the touch along the length of the fixed resistor.

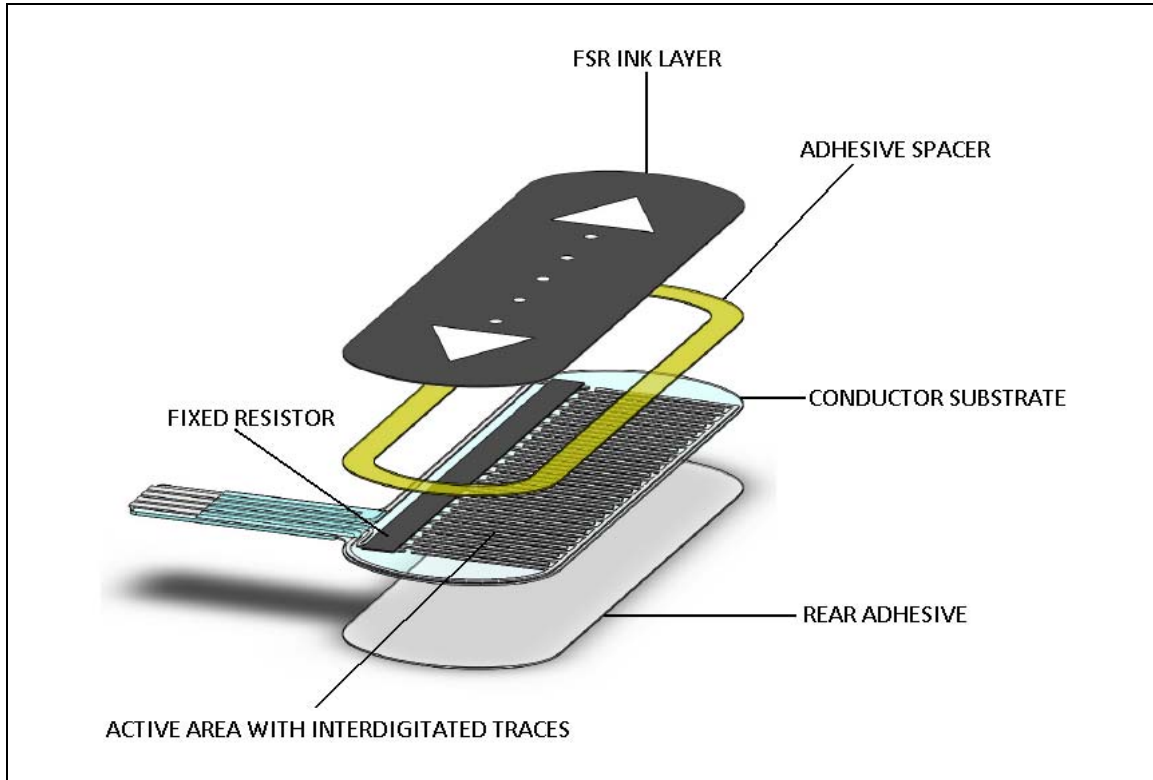

Figure 2: Exploded view of the FSLP.

Figure 3 shows a schematic view of the sensor. Notice that the sensor is a three-terminal device and when touched, has a circuit that is equivalent to three resistors. R1 is the resistance from sensor terminal 2 to the touch spot. R2 is the resistance from the touch spot down to sensor terminal 3. R_p is connected to the junction between R1 and R2 by the user's touch. As the user varies the touch spot from the top of the sensor to the bottom of the sensor, R1 becomes larger and R2 becomes smaller. As the user presses harder, R_p decreases. R_p varies from around 300kΩ at very light touches to 2kΩ at extremely heavy touches. The resistance is roughly proportional to the reciprocal of the force.

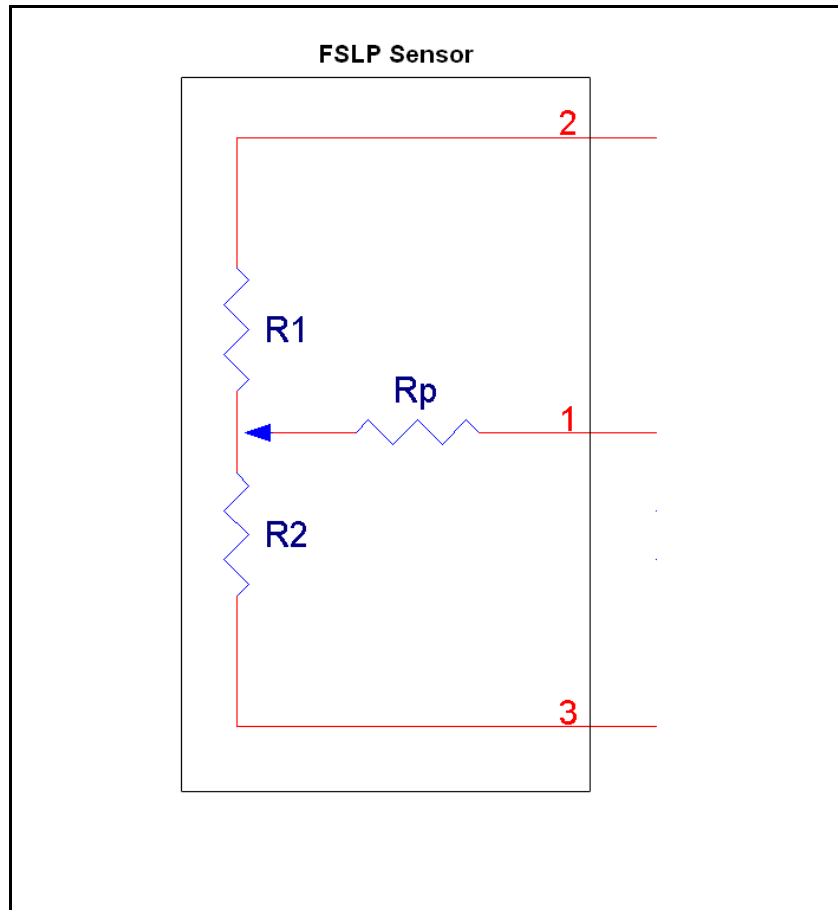

Figure 3: Schematic representation of the FSLP.

4.0 Mounting and Connection

4.1 Mounting

There are a few critical elements to consider when mounting the FSLP:

- The mounting surface should be free of any raised features (e.g. copper traces on a PCB or dust contamination) as they will interfere with the sensor's proper operation.
- If the sensor is being mounted to a PCB, it should be installed after PCB assembly is complete. Heat generated during the soldering of components can damage the FSR.
- When laminating the sensor, be sure to use a hard roller or other depression tool to ensure proper bonding of the sensor's pressure-sensitive adhesive and the removal of any air bubbles.

4.2 FSLP Types

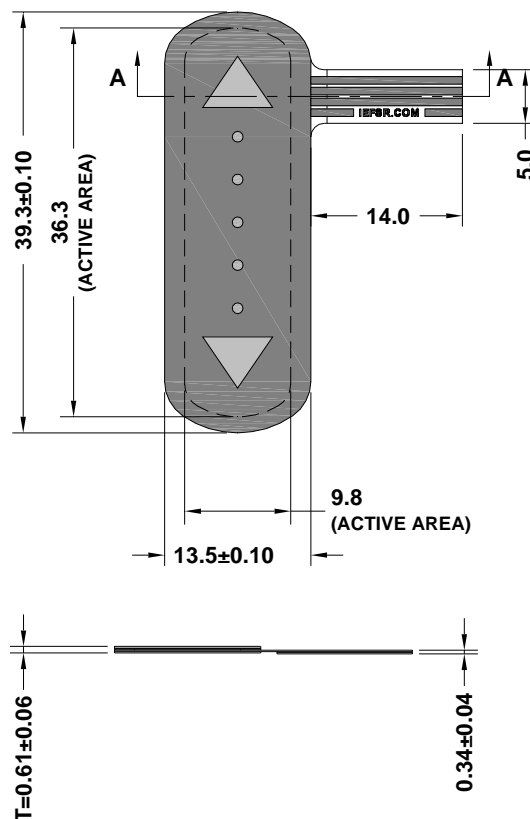

Figure 4: Overall dimensions of the standard FSLP. All dimensions are in millimeters.

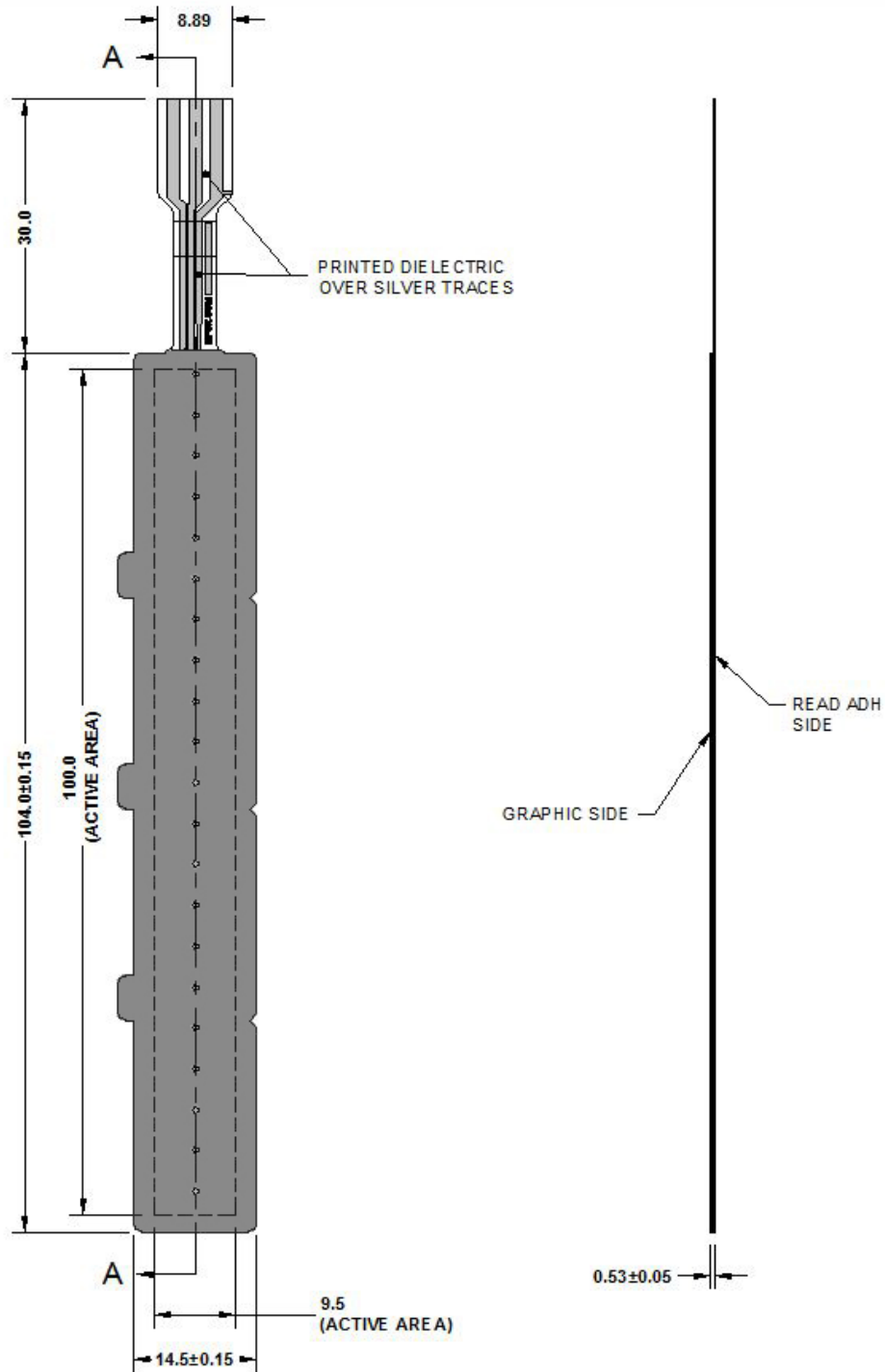

Figure 5: Overall dimensions of the 10 cm FSLP. All dimensions are in millimeters. (shown without crimp terminals)

The 10cm FSLP can be customized to shorter pre-defined lengths. Refer to User's Customization Guide provided with the Hardware Development Kit.

4.3 Crimp Terminal Connections (10cm and derivatives only)

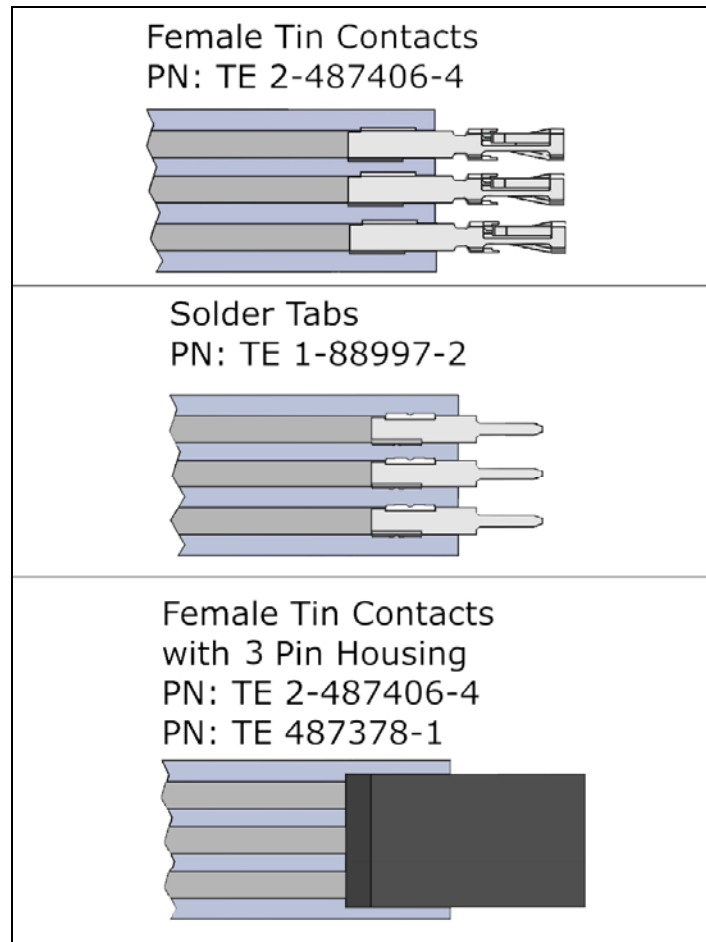

Figure 6: Crimp Terminal Connections.

4.4 FFC Connection Method

Recommended Tail Connector:
JST 4-pin SMT connector (JST Part Number: 04FM-1.0SP-1.9-TF)

Interlink recommends the above connector, but any compatible connector may be used. Refer to Figures 7 and 8 for sensor tail dimensions.

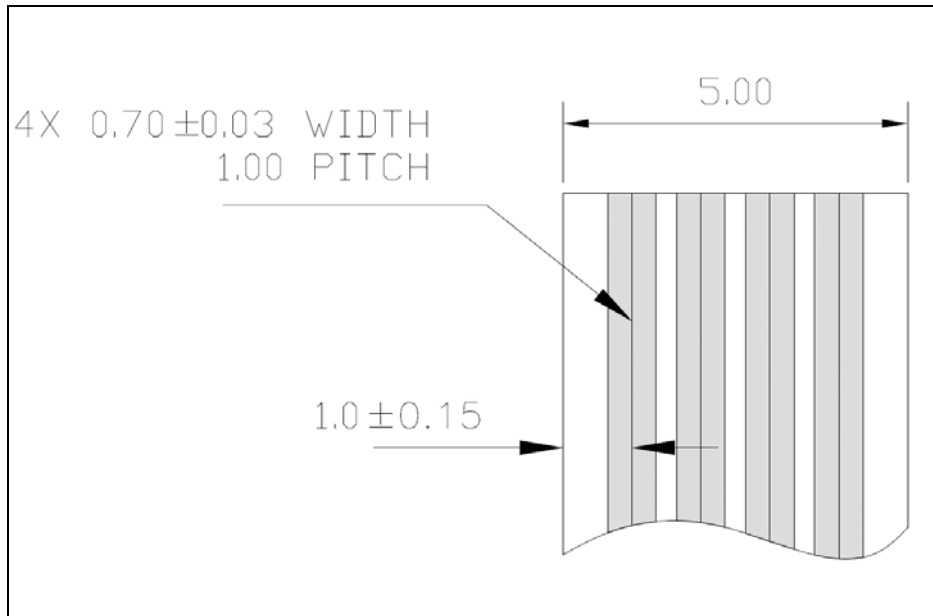

Figure 7: Top view of sensor tail. All dimensions are in millimeters.

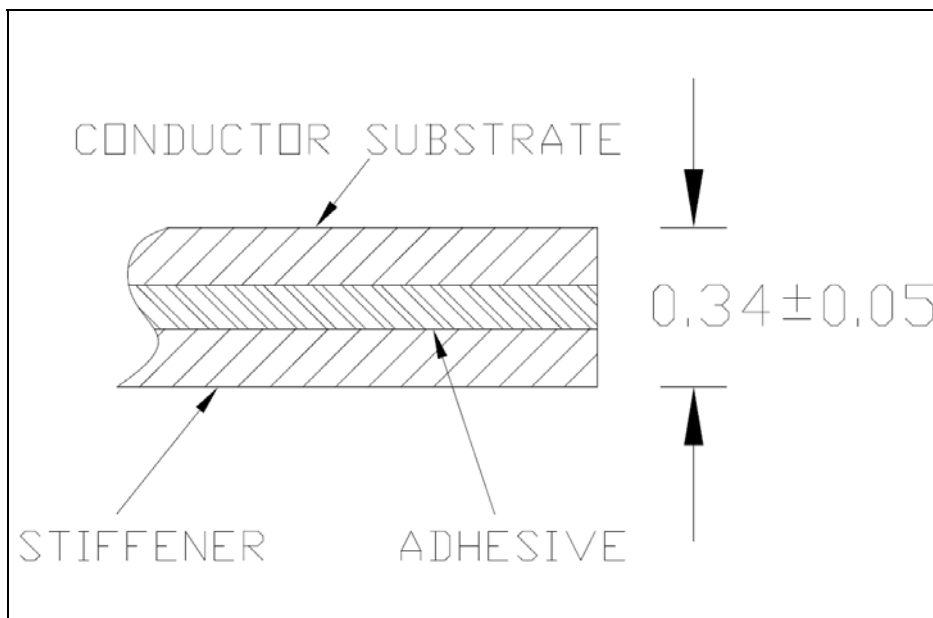

Figure 8: Side view of sensor tail. All dimensions are in millimeters.

5.0 Measurement Techniques and Algorithms

The Interlink Electronics FSLP can measure position and pressure. The connection to the measuring microprocessor is very simple and requires only one external component. The microprocessor will need two general purpose IO (GPIO) pins and two GPIO/analog-to-digital converter (ADC) pins. The GPIOs should be able to go into high-impedance mode (>1MΩ) and the ADCs should be able to measure from 0 to Vcc. The pinout for the standard FSLP and 10cm FSLP are identical.

PINOUT		
STANDARD FSLP	10 cm FSLP	REFERENCE
PIN #	PIN #	
1	3	SENSE LINE (SL)
2	1	DRIVE LINE 1 (D1)
3	2	DRIVE LINE 2 (D2)
4	4	NOT CONNECTED (NC)



Figure 9: FSLP Sensor pin out.

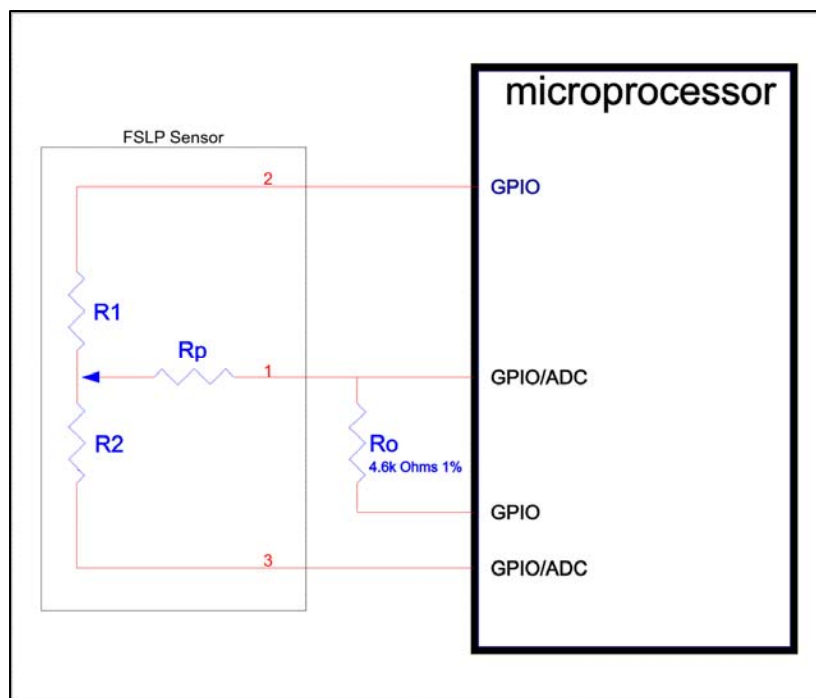

Figure 10: Circuit schematic.

5.1 Measuring Position

Step 1: Clear Charge on Sensor

- Enable all lines as outputs and set them to 0 Volts. This will clear all charge from the sensor and help reduce noise on readings.

Step 2: Set Up Appropriate Driveline Voltages

- Configure sensor terminal 2 as output high (+Vcc).
- Configure sensor terminal 3 as output low.
- Configure the pin connected to the bottom of resistor R_0 as an output low. This drains any charge that may have capacitively coupled to the sense line during the transitions of sensor terminals.
- Configure the GPIO pin connected to the bottom of R_0 as a high impedance input.
- Configure sensor terminal 1 as an ADC input.

Step 3: Wait For Voltage to Stabilize

- The voltage generated on the sense line can have an input resistance ranging from $2k\Omega$ to $300k\Omega$. Higher resistances result from very light pressure on the sensor. Depending on the input impedance of the ADC, allowing five to ten microseconds before taking the measurement will help to increase the sensitivity of the sensor and detect light touches.

Step 4: Take the measurement

- Start the A/D conversion and store the result. An 8-bit ADC will yield a result within 0 and 255 counts. This value is proportional to the physical distance from sensor terminal 3.

5.2 Measuring Pressure

Step 1: Setup the appropriate drive line voltages

- Configure sensor terminal 2 as an output high (+Vcc).
- Configure sensor terminal 1 as an ADC.
- Configure sensor terminal 3 as an ADC.
- Configure the pin connected to the bottom of R_0 as an output low.

Step 2: Wait for voltage to stabilize

- The voltage generated on the sense line can have an input resistance ranging from $2k\Omega$ to $300k\Omega$. Higher resistances result from very light pressure on the sensor. Depending on the input impedance of the ADC, allowing five to ten microseconds before taking the measurement will help to increase the sensitivity of the sensor and detect light touches.

Step 3: Take two measurements

- Take an ADC reading on the ADC connected to sensor terminal 3. Call this V1.
- Take an ADC reading on the ADC connected to sensor terminal 1. Call this V2.

Step 4: Calculate the pressure

- We know the values of V2 and R₀. Therefore, the current through R₀ can be calculated as

$$I = \frac{V2}{R_0}$$

- The current I, is the same current that flows through R_p.
- No current flows through R₂; therefore, the voltage drop across R_p is simply V1-V2.
- R_p now be calculated using:

$$R_p = R_0 \frac{V1 - V2}{V2}$$

- Because the value of R_p decreases with force, what we really want is the reciprocal of the expression above:

$$F = \frac{V2}{R_0(V1 - V2)}$$

- R₀ is a constant; therefore, we can think of it as a scaling factor. The scaling factor should be a convenient value, typically a power of 2 (e.g. 32 or 64). Choose the value of the scaling factor on an application-specific basis to yield the best data.

- The final expression is:

$$F = 64 \frac{V2}{V1 - V2}$$

6.0 Actuator

The Interlink Electronics FSLP has a protective graphic overlay; this allows for a finger or custom stylus to be used.

7.0 Orderable Part Numbers

- **Hardware Development Kit (54-00019)**
 - QTY 1 Demo Board with FSLP Standard Sensor
 - QTY 10 FSLP Standard Sensors
 - QTY 10 FSLP 10cm Sensors
 - QTY 1 Pack of 5 Connectors, 4 Pin Side Entry Female
 - QTY 1 USB Flash Drive with Product Literature
 - FSLP Integration Guide
 - FSLP Data Sheet
- **FSLP, Standard, Black Top Layer with White Graphics (34-00003)**
- **FSLP, 10cm, Sensor with Female Contacts (34-00022)**
- **FSLP, 10cm, Sensor with Solder Tabs (34-00024)**
- **FSLP, 10cm, Sensor with Female Contacts & Housing (34-00025)**
- **FSLP, 10cm, Sensor with FFC Tail (34-00034)**

8.0 Intellectual Property & Other Legal Matters

Interlink Electronics holds several domestic and international patents for its Force Sensing Resistor technology. FSR and Force Sensing Resistor are company trademarks. All other trademarks are the property of their respective owners.

The product information contained in this document provides general information and guidelines only and must not be used as an implied contract with Interlink Electronics. Acknowledging our policy of continual product development, we reserve the right to change, without notice, any detail in this publication. Since Interlink Electronics has no control over the conditions and method of use of our products, we suggest that any potential user confirm their suitability for their own application.

9.0 Contact Interlink Electronics

United States

Corporate Office

Interlink Electronics, Inc.
546 Flynn Road
Camarillo, CA 93012, USA
Phone: +1-805-484-8855
Fax: +1-805-484-9457
Web: www.interlinkelectronics.com
Sales and support: sales@interlinkelectronics.com

Japan

Japan Sales Office

Kannai-Keihin Bldg. 10F/1004
2-4-2 Ougi-cyo, Naka-ku
Yokohama-shi, Kanagawa-ken 231-0027
Japan
Phone: +81-45-263-6500
Fax: +81-45-263-6501
Web: www.interlinkelec.co.jp